

# Product Data

---

**Split System (R-410A)  
Air Handler for Multi Split  
Inverter System  
9,000 to 18,000 BTU/Hr**

---



**Console Type Indoor Unit:**

4MXF8509A10N0AA

4MXF8512A10N0AA

4MXF8518A10N0AA

# It's Hard to Stop a Trane.

## **Split System (R-410A, 60Hz) 16 SEER, Inverter System - 9,000 to 18,000 BTU/Hr**

Whatever their specific heating and cooling needs, people trust Trane to provide reliable efficient solutions. Trane Ductless Systems allow you to create a comfortable indoor environment in spaces where adding ductwork might be impractical or too expensive, or not as efficient as a ductless option.

Retrofit a house that doesn't have a ducted system or where the central system is already at capacity. Bring efficient, economical comfort to new room additions. Provide spot heating and cooling that operates independently of the central system. Utilize ductless efficiency for new construction projects where ductless systems make more sense than a traditional ducted system.

Easy to install Trane Ductless Systems offer flexibility in design and provide efficiency and economy with two simple components - an outdoor unit and one or more stylish, low profile, indoor units. All built with Trane's legendary reliability and innovative thinking.

## **Introducing the new TRANE Split System Family**



### **4MXC High Efficiency Console Indoor Unit**

#### **Quiet Operation**

Specially designed air vent efficiently reduces operation noise to provide quiet comfort, as low as 25 dB.

#### **Anti-Cold Feature**

Air is pre-heated during heating operation to prevent blowing cold air directly into the room.

#### **Compact Design**

The compact construction and simple structure make the console model easy to install and maintain.

#### **Washable Filter**

To reduce moisture on filter and provide fresh, healthy air into the room, clean filter regularly with water.

# Contents

Model Nomenclature	3
General Data	4
Unit Dimensions	5
Mechanical Specifications	6

## INDOOR UNIT MODEL NOMENCLATURE

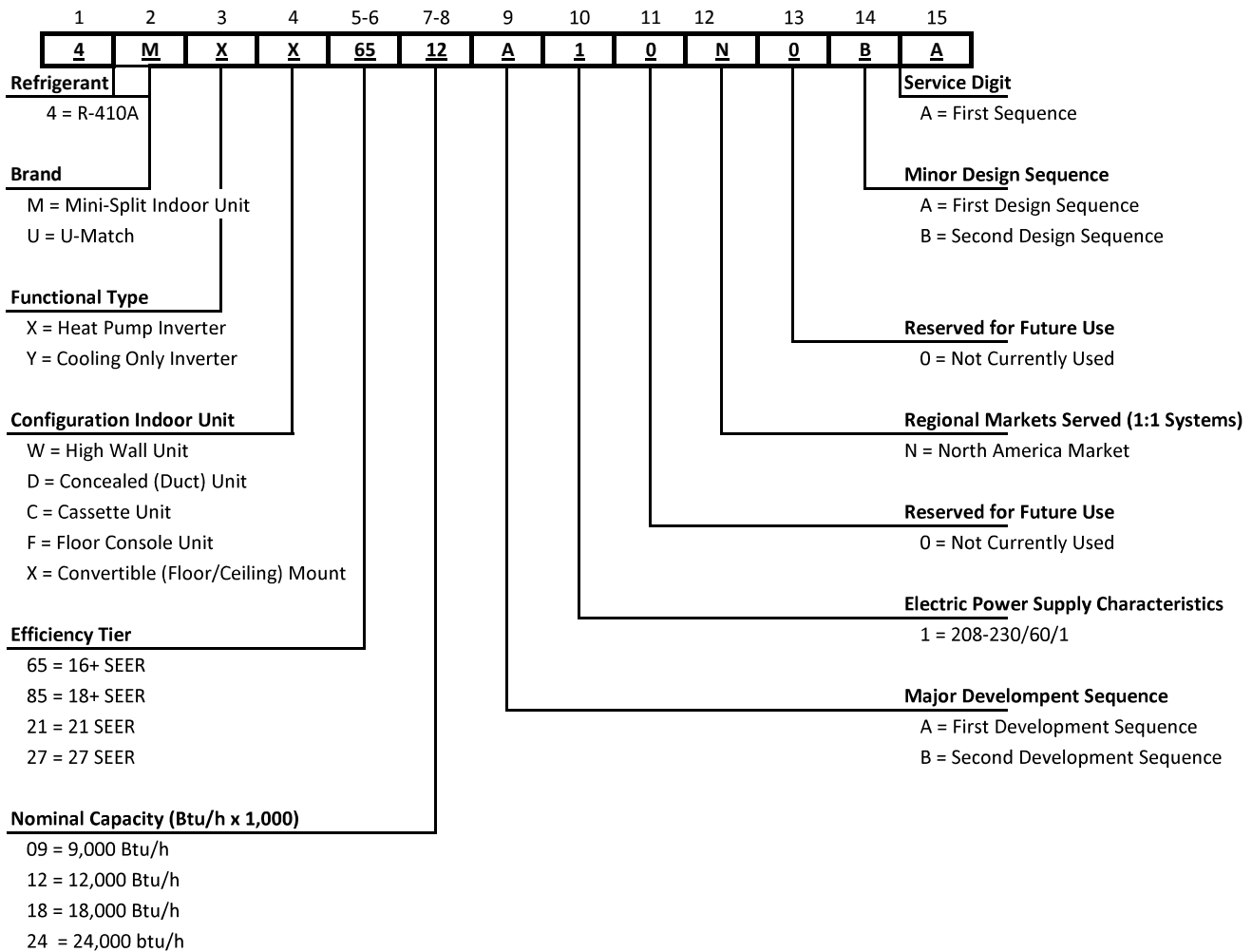

# General Data

MODEL - Console	4MXF8509A10N0AA		4MXF8512A10N0AA		4MXF8518A10N0AA	
RATED Volts/PH	208 / 230 / 1		208 / 230 / 1		208 / 230 / 1	
Frequency (Hz)	60Hz		60Hz		60Hz	
Total Cooling Capacity (Btu/h)	9000		12000		18000	
Total Heating Capacity (Btu/h)	9500		13000		19800	
Air Flow Volume (CFM) (H/M/L)	241 / 194 / 147		282 / 235 / 164		323 / 264 / 188	
Sound Power Level dB(A) (H/M/L)	46 / 40 / 35		48 / 45 / 37		54 / 47 / 43	
Sound PRESSURE Level dB(A) (H/M/L) ①	36 / 30 / 25		38 / 35 / 27		44 / 37 / 33	
Dehumidifying Volume (pint/h)	1.69		2.96		3.80	
PCB Fuse Current (A)	PCB 3.15A	Transformer 0.2A	PCB 3.15A	Transformer 0.2A	PCB 3.15A	Transformer 0.2A
Fan Quantity	1		1		1	
Fan Type	Centrifugal		Centrifugal		Centrifugal	
Motor Full Load Amp (FLA)	0.24		0.24		0.24	
Fan Motor Running Current	0.15		0.15		0.15	
Fan Motor Drive Type	Direct Drive		Direct Drive		Direct Drive	
Fan Motor Speed (RPM) (H/M/L)	530 / 430 / 320		600 / 500 / 350		720 / 580 / 410	
Evaporator Face Area (ft <sup>2</sup> )	2.17		2.17		2.17	
Evaporator Number of Rows	2		2		2	
Evaporator Fin Type	Hydrophilic film-louver fin		Hydrophilic film-louver fin		Hydrophilic film-louver fin	
Evaporator Fin Color - Blue/Not Blue	Blue		Blue		Blue	
Gas Pipe (to indoor unit) (inch)	3/8		3/8		1/2	
Liquid Pipe (inch)	1/4		1/4		1/4	
Connection Method	Flare Connection		Flare Connection		Flare Connection	
Drain Connection (inner diameter)(inch)	5/8		5/8		5/8	
Dimension (Uncrated) (W x D x H)	27.56 x 23.62 x 8.46		27.56 x 23.62 x 8.46		27.56 x 23.62 x 8.46	
Dimension (Crated) (L x W x H)	30.91 x 23.23 x 11.02		30.91 x 23.23 x 11.02		30.91 x 23.23 x 11.02	
Net Weight (lbs)	33.1		33.1		33.1	
Gross Weight (lbs)	39.7		39.7		39.7	

① Sound PRESSURE Level @ 3.3 ft. dB(A)

# Unit Dimensions

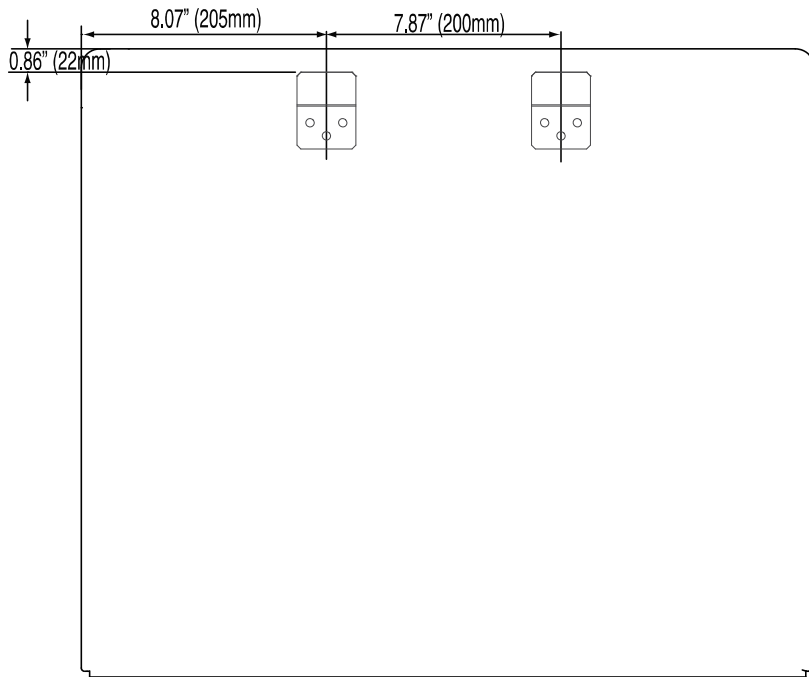
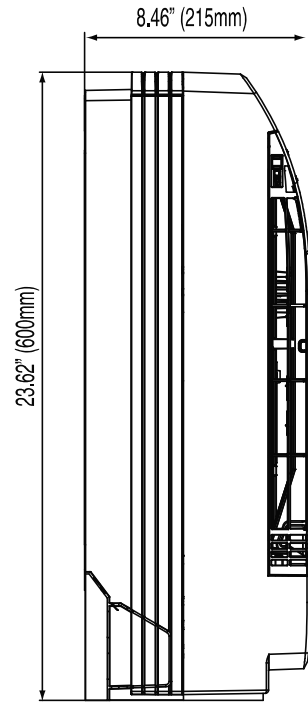
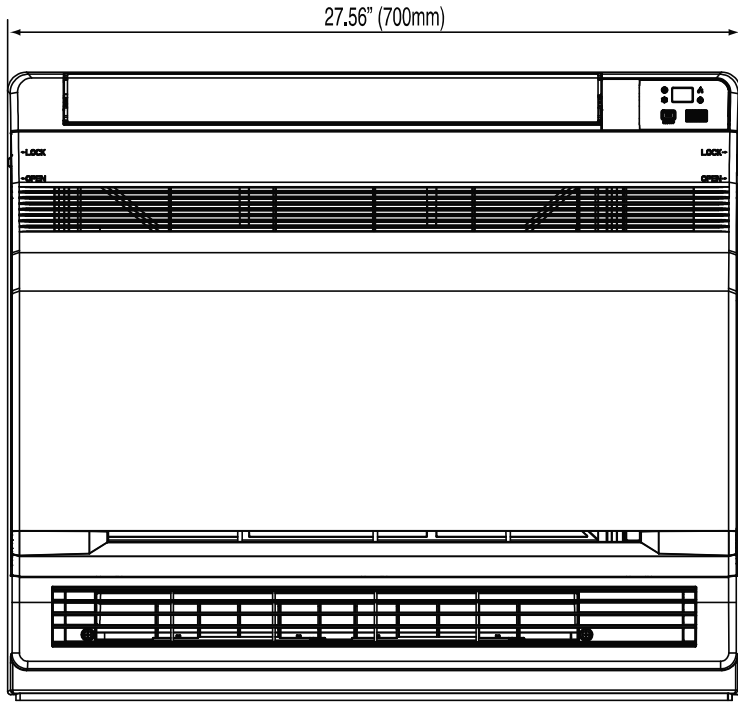

Schematic drawing of hooks:

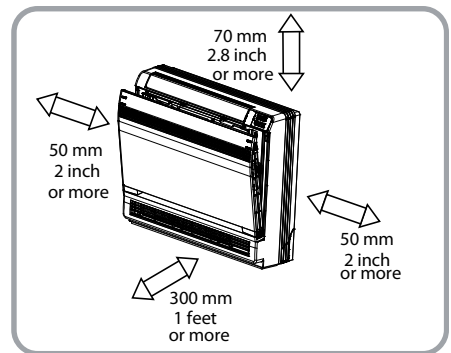
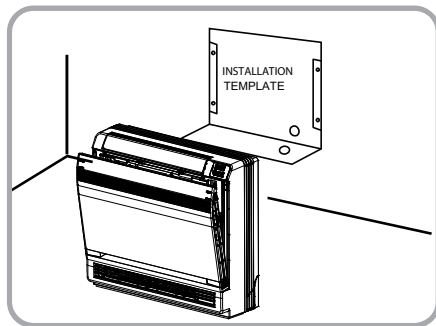
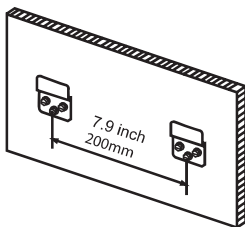

# Mechanical Specifications

---

## ConsoleType Unit

### General

The Console type air handler shall be completely factory assembled including coil, condensate drain pan, fan motor, washable filter and electric controls to be used with a remote controller. Unit shall be matched with a Trane outdoor unit, rated and tested in accordance with AHRI standard. Unit shall be ETL listed.

### Unit Casing

Casing shall be provided with drain hose to facilitate piping and electrical connection on the right side of the unit. An electrical service cover shall be provided to permit easy access to the electrical terminal strip.

### Discharge Airflow and Distribution System

Unit shall have auto swing, dual horizontal blades to optimize the aperture outlet for vertical airflow and air distribution. Blade shall close automatically when the air conditioner is turned off to minimize dust entering the unit. Five-Step preset program on the remote controller shall be available to control the blade angle.

Manually adjusted wide-angle louvers shall be provided to adjust the coverage and direction of airflow.

### Controls

Units shall have the capability to be controlled remotely.

### Remote Controller

The unit shall have a wireless infrared remote controller with easy reading digital display panel to start, stop and regulate the air conditioner from a distance.

The wireless controller is available for all units. **(Sold separately)**

### Washable Filtration

The unit shall have an easy clean, washable filter which allows for cleaning when needed. Clean filters provide optimum efficiency and fresh air into the room.



**Trane**  
6200 Troup Highway  
Tyler, TX 75707-9010

06/14

The manufacturer has a policy of continuous product and product data improvement **and** it reserves the right to change design and specifications without notice.